

1/4" Anti Vandal Dome Camera

SCC-931TP



Features

- ▶ Clear screen quality with over 480 lines of horizontal resolution
- ▶ Minimum illumination
 - : 1 Lux(30IRE, Sense Up Off)
 - : 0.01 Lux (30IRE Sense Up x128)
- ▶ Camera ID
 - : Maximum 12 characters (Capable of a location setting)
- ▶ Backlight Correction Function
- ▶ White Balance Function
- ▶ Motion Detection Function
- ▶ Remote Control : RS485 (Half Duplex)

Video Security Systems

SCC-931TP

Specifications

Model	SCC-931TP
Scanning System	625lines, 25frame/sec (PAL)
Image Size	1/4" 470,000 pixels
Picture Elements	795(H) X 596(V) ; Total Picture Elements
Synchronizing System	Internal/Line Lock
Interlace	2 : 1 Interlace
Resolution	480 TV Lines
Video Output Level	VBS 1.0Vp-p, 75Ω, BNC
S/N	50db
Min. Scene Illumination	• 1 Lux (30IRE) • 0.01 Lux (30IRE, Sense Up x128)
Electronic Shutter	Off ~ 1/10,000 sec
Back Light Compensation	On/Off (Area/Position setting)
Sense Up	Max. 128x (Auto/Fix/Off)
Motion Detection	On/Off
Focus	AF/One AF/Manual
Viewing Angle	Wide : 52°.8'(H) x 40°.3'(V) Tele : 4°.7'(H) x 3°.6'(V)
Lens	• Focal length : 3.6 ~ 43.2mm • x120 (12x Optical Zoom, 10x Digital Zoom)
Environmental Conditions	• Operating Temperature : -10 ~ 50°C(14 ~ 122°F) • Humidity : Within 90% RH
Power Requirement	AC24V/DC12V, 50Hz
Power Consumption	Approx. 6W
Weight	Approx. 1kg
Dimensions (φ x H)	132(φ) x 95.3mm



Dimensions

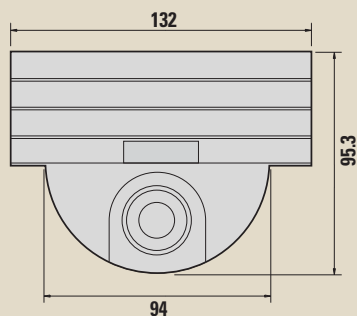

SCC-931TP



Samsung Electronics Co., Ltd.
HPS Marketing Group

416, Maetan-3Dong, Paldal-Gu, Suwon City, Kyungki-Do, Korea 442-742
TEL : +82-31-200-9006 FAX : +82-31-200-5594
Internet Website : <http://www.securitysamsung.com>

Distributed by:

* Design and specifications are subject to change without notice.